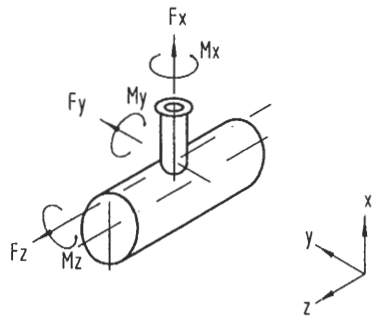

TABLE OF ALLOWABLE NOZZLE LOADS



NOZZLE		FORCES (KN)			MOMENTS (KNM)	
MARK	DN	F _x (+or-)	F _y	F _z	M _x	M _y
N1	6"	1,6	1,6	1,6	1,6	1,6
N2	6"	1,6	1,6	1,6	1,6	1,6
N3	6"	1,6	1,6	1,6	1,6	1,6
N4	6"	1,6	1,6	1,6	1,6	1,6

18.2.03 by

Gemessene Maße in Klammern [] !
Measured dimensions are in parenthesis [] !

12	SA194GR2H Hex.nut	1/2"UNC		32	
11	SA193B7 Stud bolt	1/2"UNC x 2.5"		16	
10	SA182/F304 Blindflange	DN 1" 150 lbs RF	ANSI B16.5	4	
9	EPDM Gasket	Diam. 52x3		4	
8	EPDM Gasket	Diam (1580) x 3		2	
7	Carb.steel Washer	Dia. 31	DIN ISO 7090	80	
6	SA194GR2H Hex nul	1 1/8"-8UN		80	
5	SA193B7 Hook claw	For 1 1/8"		80	
4	SA193B7 Hook bolt	1 1/8"-8UNx250		80	
3	OUTER COVER		07.16095-181	1	1300
2	INNER COVER		07.16095-171	1	1300
1	SPIRAL BODY		07.16095-151	1	8050
Item	Material/Part Drawings	Dimensions	Code	Qty	Weight kg

Removable fitting pieces or intermediate pieces in piping between Spiral Heat Exchanger nozzles and piping are recommended.

Instructions in Spiral Heat Exchanger handbook / installation operation and maintenance manual have to be followed for ALL work on Spiral Heat Exchanger

NOZZLES

	DN	DESCRIPTION	STAND.	PN	TYPE	REMARKS
N1	6"	Inlet Inner channel, hot side	ANSI 16.5	1501b	WN	RF
N2	6"	Outlet Inner channel, hot side	ANSI 16.5	1501b	WN	RF
N3	6"	Inlet Outer channel, cold side	ANSI 16.5	1501b	WN	RF
N4	6"	Outlet Outer channel, cold side	ANSI 16.5	1501b	WN	RF
N5	1"	Vent Inner channel, hot side	ANSI 16.5	1501b	WN	RF blind
N6	1"	Drain Inner channel, hot side	ANSI 16.5	1501b	WN	RF blind
N7	1"	Vent Outer channel, cold side	ANSI 16.5	1501b	WN	RF blind
N8	1"	Drain Outer channel, cold side	ANSI 16.5	1501b	WN	RF blind

THE DRAWING CONTAINS INFORMATION WHICH IS THE PROPERTY OF VAAHTO PROCESS MACHINERY. IT IS TO BE USED ONLY FOR THE PROJECT AND FOR WHICH IT IS ISSUED. IT IS NOT TO BE REPRODUCED OR TRANSMITTED IN ANY FORM OR BY ANY MEANS, ELECTRONIC OR MECHANICAL, INCLUDING PHOTOCOPYING, RECORDING, OR BY ANY INFORMATION STORAGE AND RETRIEVAL SYSTEM, WITHOUT THE WRITTEN CONSENT OF VAAHTO PROCESS MACHINERY.	Finish	Point Height
	Nimitys/Title	Part/Drawn
	Spiral Heat Exchanger 272m ² /2928ft ²	16.03.2008
	AS-Built Drawing H-350	MHO
Asiakas/Customer	Hyv./Appr	
Walbridge Southern	Proj/Job No	16095150
	Lititty/Assoc.to	
	As pir./ cust. dwg	
VAAHTO PROCESS MACHINERY	Manuf.series	3
	Model proj.	
Scale 1:15	Piirno/Dwg.no	07.16095-150-AB
	Koko Size	A1
	Rev	0